

# Artiman

## Hydraulic Powers



طراحی و ساخت تجهیزات هیدرولیک صنعتی و ماشین سازی (مجموعه ها و قطعات یدکی)



شرکت نیروساز هیدرولیک آرتیمان، فعالیت خود را در زمینه هیدرولیک صنعتی و ماشین سازی (مجموعه‌ها و قطعه‌های یدکی) آغاز کرده است. این شرکت محصولات خود را با به کارگیری آخرین تکنولوژی روز دنیا و با تکیه بر کادر فنی و مهندسين مجرب، با بالاترين کیفیت و قدرت قابل اطمینان تولید و روانه بازار می‌کند.



محصولات آرتیمان جزو کاربردی ترین ابزارها در صنایع مختلف از جمله نفت و گاز، پتروشیمی، فولاد، معادن و ... است. این شرکت با تولید ابزارهای صنعتی کاربردی در صنایع مختلف، قدرتی انعطاف پذیر و قابل کنترل، حداکثر تا ۱۵۰۰ بار ارائه می‌دهد.



هدف این شرکت بومی سازی ابزارهای هیدرولیکی صنعتی و پیاده سازی راهکارهای سیستماتیک در صنایع مختلف می‌باشد تا نیاز به کالاهای خارجی را در بخش‌های مختلف صنایع کشور برطرف سازد. ابزارهای آرتیمان این توان را به اپراتور می‌دهد تا نیروهای هیدرولیکی عظیم کاربردی و کنترل شده را به صورت ایمن حتی در نامساعدترین شرایط بکار گیرد.



علاوه بر طراحی و تولید محصولات هیدرولیکی صنعتی فشار بالا به صورت استاندارد، سرمایه‌گذاری در توسعه محصولات هیدرولیکی، برای حفظ موقعیت پیشرو در صنایع جزو اهداف اصلی مدیریت است. این شرکت توانایی پاسخگویی به نیازهای منحصر به فرد مشتریان (محصولات سفارشی در زمینه هیدرولیک صنعتی و ماشین‌سازی) با ترکیب دانش مهندسی و نیاز مشتری را دارد. همچنین انجام آزمایش‌های سختگیرانه در مراحل مختلف تولید جزو الزامات این شرکت است.

**امکان تولید کلیه محصولات به صورت سفارشی متناسب با نیاز کارفرما وجود دارد.**

**محصولات آرتیمان شامل ۱ سال کارانتی و ۱۰ سال خدمات پس از فروش می‌باشند.**

## Hydraulic Nut Cutter- NC

## مهره بر هیدرولیکی



### NC series

- Single acting, spring return cylinder
- Unique angled head allows flush access
- Compact and ergonomic design, easy to use
- Applications include servicing trucks, piping industry, petrochemical, steel industry and mining
- Max working pressure 700 bar

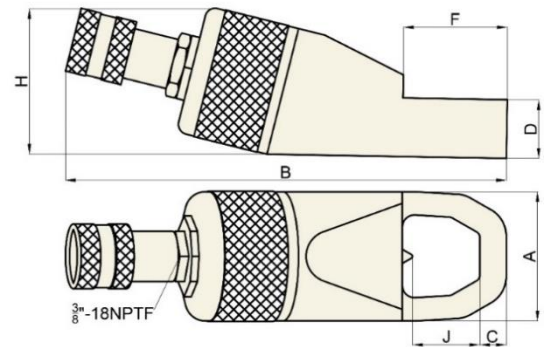

Nut Cutter Model	Bolt Range (mm)	Hexagon Nut Range	Capacity (ton)	Oil Capacity (cm <sup>3</sup> )	Weight (kg)	Dimension (mm)						Replacement Blade Number	
						A	B	C	D	F	H		J
NC 1319	M8-M12	13-19	5	15	1.2	40	170	7	19	28	48	21	NC.B 1319
NC 1924	M12-M16	19-24	10	20	2.0	54	191	10	26	40	62	25	NC.B 1924
NC 2432	M16-M22	24-32	15	60	3.5	64	222	13	29	51	72	33	NC.B 2432
NC 3241	M22-M27	32-41	20	80	5.9	75	244	17	36	66	88	43	NC.B 3241
NC 4150	M27-M33	41-50	35	155	10.5	94	288	21	45	74	105	54	NC.B 4150
NC 5060	M33-M39	50-60	50	240	15.1	106	318	23	54	90	128	60	NC.B 5060
NC 6075	M39-M48	60-75	90	492	39.5	156	393	26	72	110	181	80	NC.B 6075

Hydraulic Nut Splitter- DNS

مهره بر هیدرولیکی سنگین



DNS series

- Angled body design for increased clearance on flanges and flat surfaces
- High quality steel construction
- Designed to fit on most API and ANSI flanges
- Max working pressure 700 bar

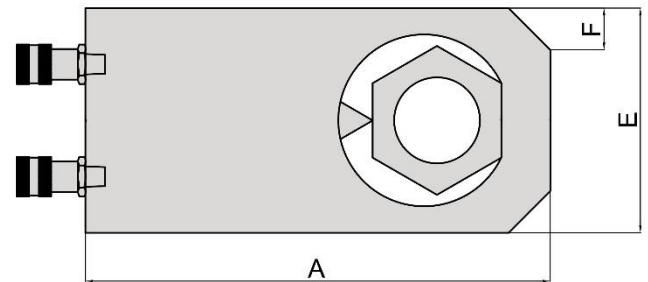
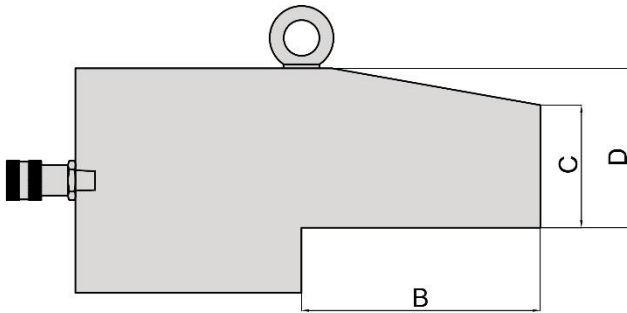

Nut Splitter Model	Capacity (ton)	Oil Capacity (cm <sup>3</sup> )	Hexagon Nut Range (mm)	Bolt Range	Weight (kg)
DNS 404	119.6	796	75-105	M48-M72	50
DNS 506	203.4	1510	105-136	M72-M95	96

Nut Splitter Model	Dimension (mm)					
	A	B	C	D	E	F
DNS 404	379.5	192	99.5	130.5	183	34
DNS 506	451	240	140	167.5	235	41

## Bolt Tensioner- SBT

پیچ کش



### SBT series

- Fit all standard flanges including ANSI and API
- Lightweight and easily handled design
- Quick-Release bridge and Hex. Socket design for fast change over
- nickel plating prolongs tool life and reduces on the job maintenance
- Improved seal design offers increased reliability
- Simple and easy to maintain

Model	SBT-20	SBT-35	SBT-50	SBT-60	SBT-90	SBT-130	SBT-160	SBT-200	SBT-250	SBT-310
Bolt Dimension (Diameter × Pitch)	M20 × 2.5	M27 × 3	M36 × 4	M42 × 4.5	M45 × 5	M60 × 5.5	M72 × 6	M80 × 6	M100 × 6	M125 × 6
	M22 × 2.5	M30 × 3.5	M39 × 4	M45 × 4.5	M48 × 5	M64 × 6	M76 × 6	M85 × 6	M110 × 6	M130 × 6
	M24 × 3	M33 × 3.5	M42 × 4.5	M48 × 5	M52 × 5	M68 × 6	M80 × 6	M90 × 6	M120 × 6	M140 × 6
	M27 × 3	M36 × 4	M45 × 4.5	M52 × 5	M56 × 5.5	M72 × 6		M95 × 6	M125 × 6	M150 × 6
					M60 × 5.5	M76 × 6		M100 × 6		
Max working Pressure (bar)	150	150	150	150	150	150	150	150	150	150
Hydraulic Area (cm <sup>2</sup> )	20	35	50	60	90	130	160	200	250	310
Max Hydraulic Load (KN)	300	525	750	900	1350	1950	2400	3000	3750	4650
Piston Stroke (mm)	8	8	8	8	8	8	10	10	10	10

Flange Spreader- SW

فلنج بازکن گوه ای

هیدرولیکی



مکانیکی



## Flange Spreader- SW

## فلنج بازکن گوه ای

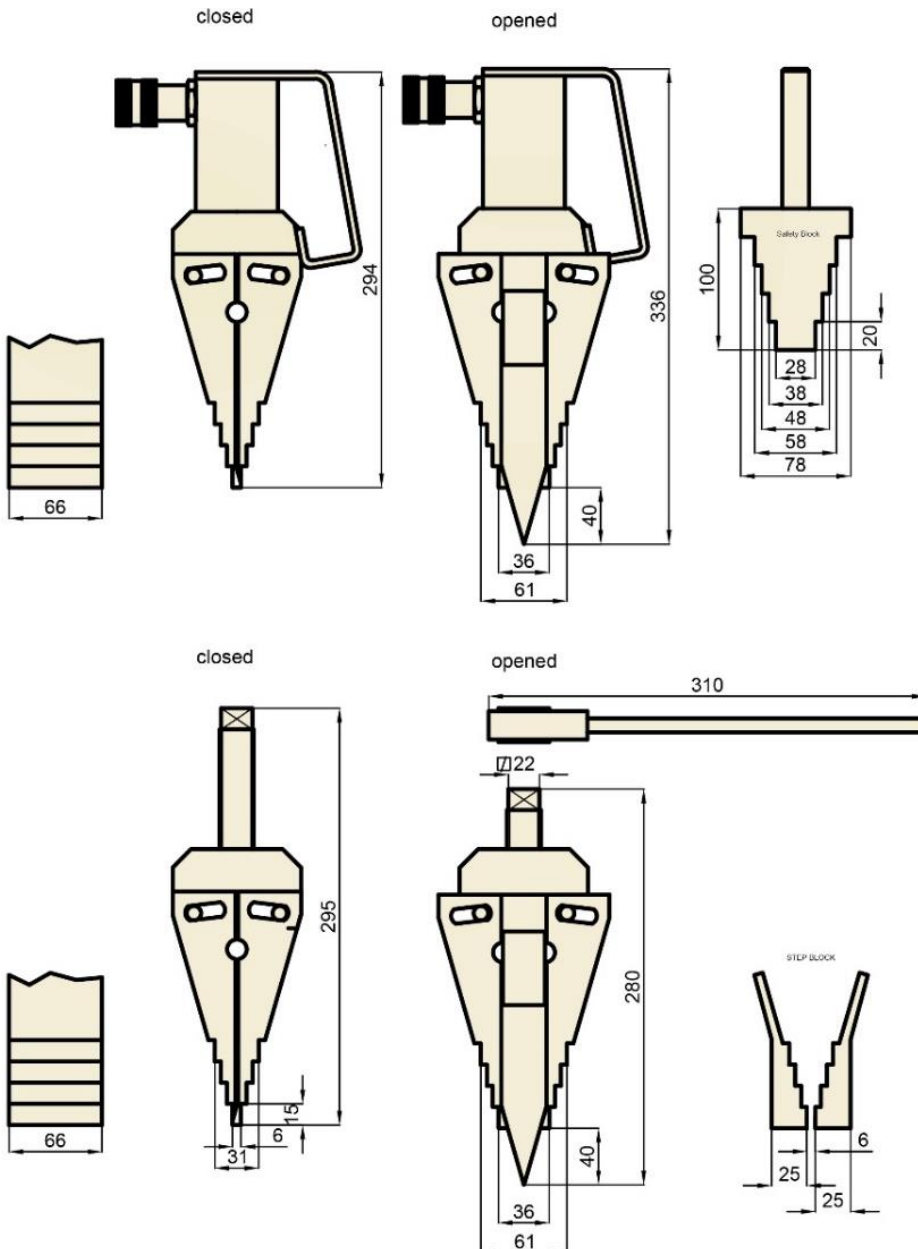

### SW-14H

- Only requests an access gap of 6mm
- Automatic mechanical retraction
- Unique interlocking : no first step bending and risk of slipping out of joint
- Max working pressure 700 bar

### SW-8M

- Only requests an access gap of 6mm
- Unique interlocking : no first step bending and risk of slipping out of joint
- No need for hydraulic tools

Model	Maximum Spreading Force (ton)	Tip Clearance (mm)	Maximum Spread (mm)	Spreader Type	Oil Capacity (cm <sup>3</sup> )
SW-14H	14	6	80	Hydraulic	78
SW-8M	8	6	80	Mechanical	-

Hydraulic Flange spreader- SP

فلنج بازکن پینی



SP series

- Lightweight, ergonomic design for ease of use.
- Adjustable jaw widths from 70-216 mm for a wide range of applications.
- Single-acting, spring return RSC-Series cylinder for fast trouble free operation.
- Max working pressure 700 bar



Model	Maximum Flange Thickness (mm)	Stud Size (mm)	Standard Wedge (mm)	Capacity (ton)	Stroke (mm)	Oil Capacity (cm <sup>3</sup> )
SP-5H	2×57	19-28	3-28	5	38	24.6
SP-10H	2×92	31-41	3-28	10	54	78.7

Dimensions (mm)											
Model	A	B	C		D	E	F	H	I	J	Weight (kg)
			Min	Max							
SP-5H	76	209	70	155	32	196	88	25	206	19	12
SP-10H	108	279	104	216	50	152	114	38	273	31	18.5

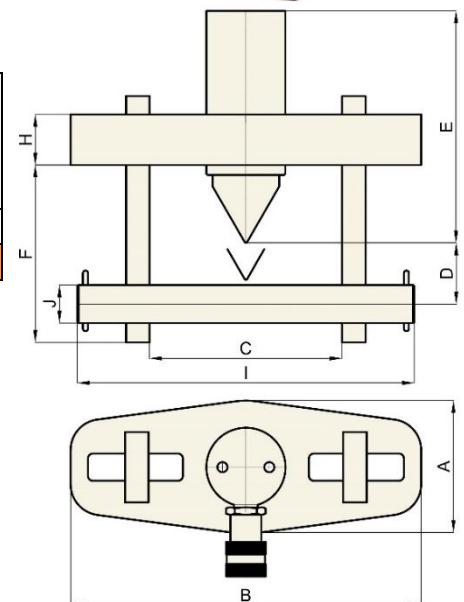



## Hydraulic Vertical Lifting Wedge - LW

## گوه بالابر عمودی هیدرولیکی

### LW Series

- **Maximum Lifting Force**  
**16 ton**
- **Lifting Stroke**  
**21 mm**
- **Maximum Operating Pressure**  
**700 bar**
- **Tip Clearance / Maximum Spread**  
**10 mm / 81.5 mm**



- Requires very small access gap of only 10 mm.
- Lifting force 16 ton at 700 bar hydraulic pressure.
- Each step can spread under full load.
- Straight vertical lifting .
- Unique interlocking wedge design: no first step bending and risk of slipping out
- Single-acting , spring return cylinder.
- Lifting wedge LW-16 includes safety block SB-2
- Includes RC-Series Cylinder with CR-400 Coupler

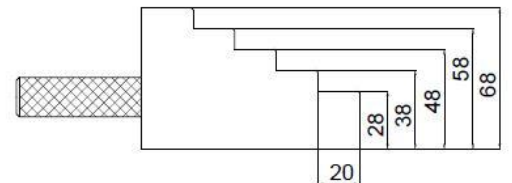
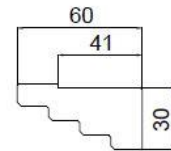
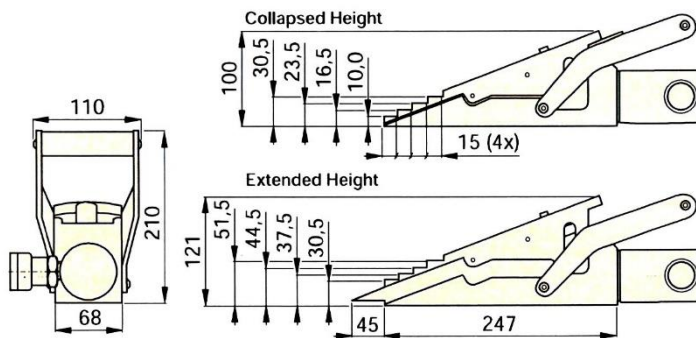

Model	Maximum Lifting Force ton(KN)	Lifting Stroke (mm)	Tip Clearance (mm)	Maximum Operating Pressure (bar)	Oil Capacity (cm <sup>3</sup> )	(kg)
LW-16	16 ( 157)	21	10	700	78	9.0

Hand Pump

پمپ دستی



P392



16P80



P80A

Pump series

- wide oil capacity range, suitable for different applications
- two speed auto switch reduces manpower and increase efficiency
- non-conductive fiberglass handle for operator safety

Model	Usable oil capacity (cm <sup>3</sup> )	Pump type	Pressure rating (bar)		Oil displacement per stroke (cm <sup>3</sup> )		Max handle effort (Kg)
			1 <sup>st</sup> stage	2 <sup>st</sup> stage	1 <sup>st</sup> stage	2 <sup>st</sup> stage	
P392	900	Two speed	25	700	32	2.5	7.2
P80	2500	Two speed	25	700	32	2.5	8
P801	4400	Two speed	25	700	32	2.5	12
P80A	2500	Two speed	25	700	32	2.5	11
16P80	1500	Two speed	15	1600	32	2.5	8.5

## Hydraulic foundry Wedge

## راهگاه شکن هیدرولیکی



Model	Maximum Force ton(KN)	Stroke (mm)	Ideal Tip Clearance (mm)	Tip Clearance (mm)	Maximum Clearance (mm)	Maximum Operating Pressure (bar)	Oil Capacity (cm <sup>3</sup> )	(kg)
HFW-3025	16 ( 157)	72	55	42	70	240	362	45

با استفاده از راهگاه شکن هیدرولیکی تولیدی شرکت آرتیمان جداسازی راه گاه قطعات فولادی و چدن داکتیل ریخته گری شده به راحتی و بدون آسیب به محصول انجام میگردد .  
گوه های این محصول با توجه به درخواست و نیاز مشتری طراحی می شود .

Valve wheel spanner

آچار ولو

آچار ولو های تولیدی شرکت آرتیمان به علت طراحی بهینه شده که در قسمت درگیر با فلکه دارد، ایمن بوده و استفاده از ابزار را ساده تر و آسیب به اپراتور را غیرممکن می سازد. این آچارها از فولاد آلیاژی خاص و با بهره گیری از تکنولوژی برتر به صورت یکپارچه و بدون جوش تولید می شود. آچارها در ۶ سایز استاندارد طبق جدول فوق تولید می شود. در صورت نیاز مشتری به آچار مخصوص شرکت توان تولید آن را دارد.



- باز کردن دریچه های مسدود شده، خورده شده و بیش از حد سفت شده با حداقل نیرو
- اعمال نیروی چند برابر بیشتر از نیرویی که اپراتور می تواند با دست اعمال کند.
- اعمال نیروی موثر و ایمن به دلیل درگیری مناسب
- مورد استفاده در انواع صنایع از جمله نفت و گاز، پالایشگاه، فولاد و ...



## Valve Wheel Spanner

## آچار ولو



WS 54-800-50

کد آرتیمان

15-24 inch

سایز

2511530b02160006

ایران کد



WS 46-550-43

کد آرتیمان

11-16 inch

سایز

2511530b02160005

ایران کد



WS38-450-35

کد آرتیمان

7-12 inch

سایز

2511530b02160004

ایران کد



WS 28-340-25

کد آرتیمان

3-8 inch

سایز

2511530b02160003

ایران کد



WS 20-195-17

کد آرتیمان

1-4 inch

سایز

2511530b02160002

ایران کد



WS 16-075-10

کد آرتیمان

Up to 2 inch

سایز

2511530b02160001

ایران کد

Spanner type	D (mm)	W (mm)	L (mm)	Size (Inch)	Weight (kg)
WS 16-075-10	16	32	230	Up to 2	0.3
WS 20-195-17	20	44	340	1-4	0.4
WS 28-340-25	28	58	460	3-8	0.8
WS 38-450-35	38	71	534	7-12	1
WS 46-550-43	46	92	700	11-16	2.5
WS 54-800-50	54	118	900	15-24	4.5

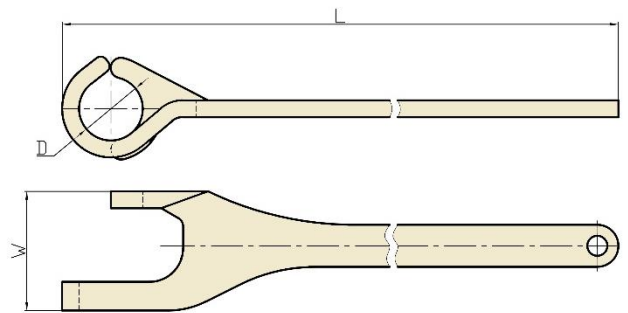

Flexible Coupling

کوپلینگ بوش دار منعطف

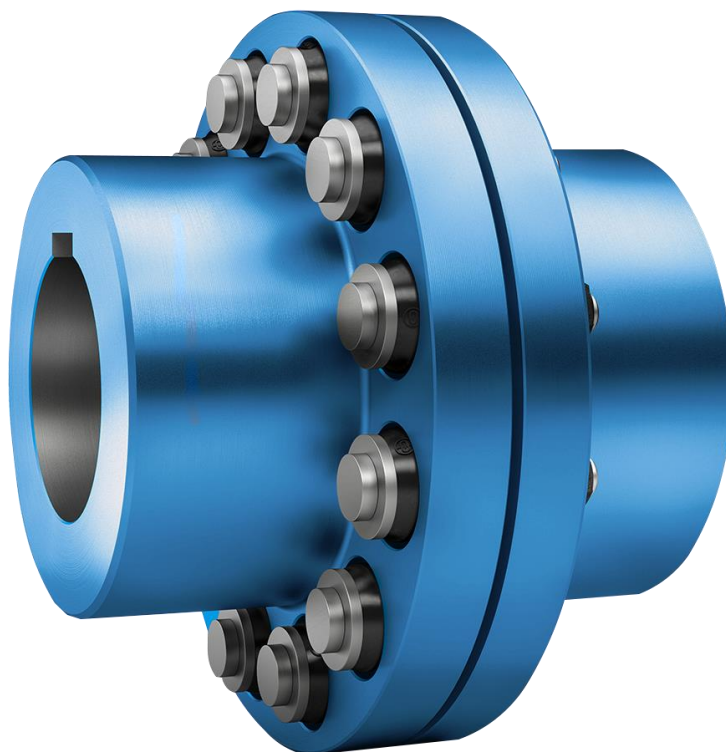
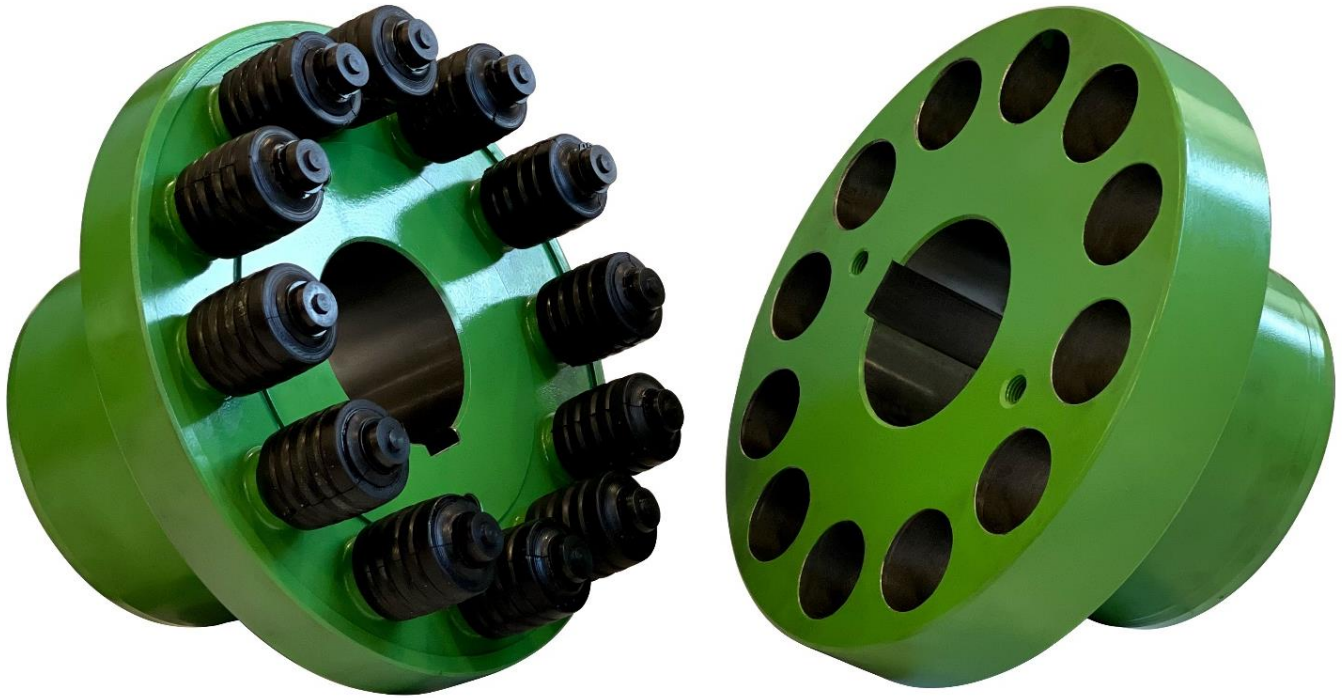

## Flexible Coupling

## کوپلینگ بوشی دار منعطف

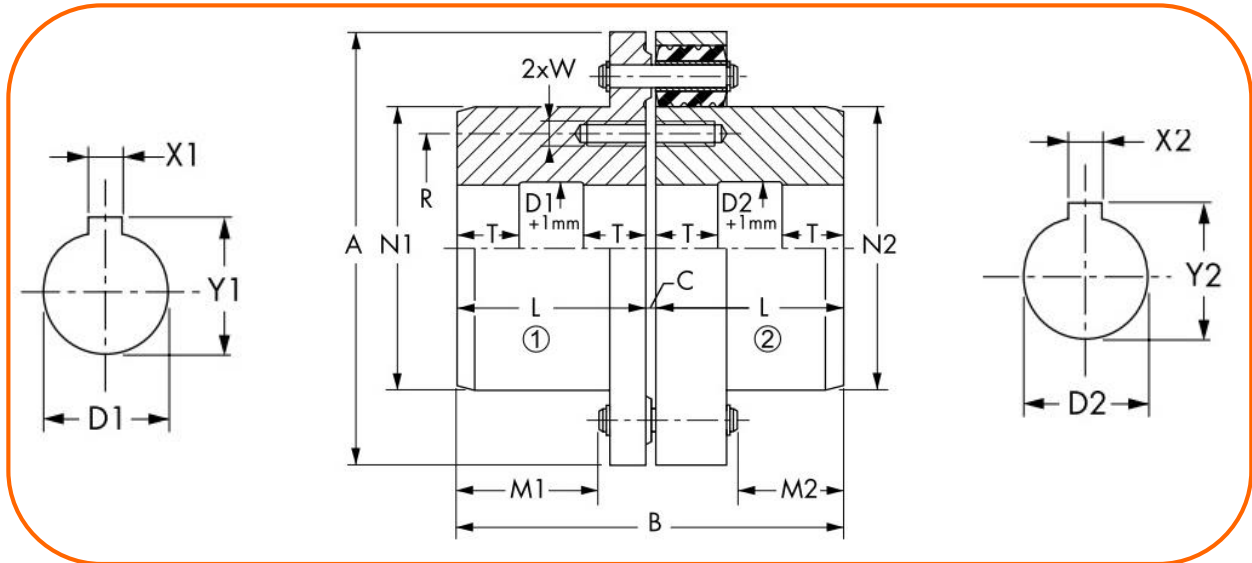

Dimensions (mm)

size	T <sub>N</sub> (Nm)	n <sub>max</sub> min <sup>-1</sup>	D1 D2 min.	D1 max.	D2 max.	A	B	C	L	M1	M2	N1	N2	T	R	W	J (Kg <sup>m2</sup> )	m (Kg)
145LL	250	4700	19	60	55	145	113.5	3.5	55	36	16.5	93	88	-	75	M8	0.016	8
155LL	400	4400	19	65	60	155	123.5	3.5	60	41	21.5	100	95	-	80	M8	0.021	9
175LL	630	3900	28	75	75	175	153.5	3.5	75	56	36.5	116	116	-	95	M10	0.04	14
200LL	1000	3400	35	85	80	200	183.5	3.5	90	71	51.5	132	127	-	105	M10	0.071	21
235LL	1600	2900	35	95	90	235	204	4	100	65	48	147	142	-	120	M12	0.175	34
245LL	2500	2800	35	110	100	245	224	4	110	75	58	170	160	-	135	M12	0.235	42
280LL SS	3900	2450	85 35	125 85	110 85	280	264	4	130	95	78	195 155	180 155	-	145	M12	0.43 0.34	56 50
315LL SS	6100	2200	100 45	140 100	125 100	315	304	4	150	115	98	217 180	202 180	-	165	M12	0.72 0.59	76 71
355LL SS	9300	1950	120 75	160 120	140 120	355	365.5	5.5	180	129	108	248 210	228 210	-	190	M16	1.53 1.33	119 119
385LL SS	14000	1800	130 85	180 130	160 130	385	405.5	5.5	200	149	128	280 230	256 230	-	220	M16	2.41 1.95	161 150
460LL SS	21000	1500	140 95	200 160	200 160	460	445.5	5.5	220	169	148	290 250	290 250	-	232	M20	4.35 3.65	220 210
510LL SS	31000	1350	160 110	220 180	220 180	510	487	7	240	162	144	320 280	320 280	80	260	M20	8.5 7.6	315 310
575LL SS	45000	1200	160 125	230 190	230 190	575	527	7	260	182	164	330 290	330 290	85	300	M24	12.9 11.8	410 385
670LL SS	65000	1100	180 140	260 210	260 210	670	587	7	290	212	194	365 325	365 325	95	320	M24	23.5 21.5	560 540

Gear Coupling

کوپلینگ دنده ای





## Gear Coupling

## کوپلینگ دنده ای

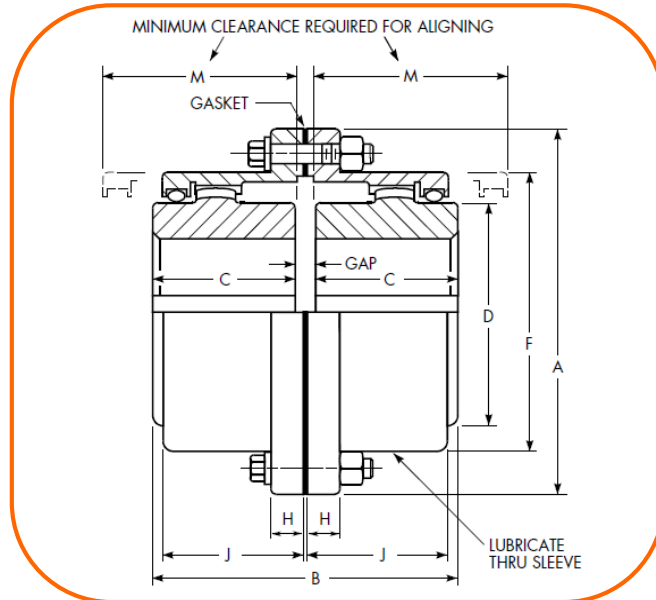

Dimensions (mm)

size	Torque Rating (Nm)	Allow speed RPM	Max Bore	Min Bore	Weight with no bore (kg)	A	B	C	D	F	H	J	M	GAP
1010G	1140	8000	50	13	4.54	115.9	89	43	68.6	83.8	14	38.9	51	3
1015G	2350	6500	65	20	9.07	152.4	102	49	86.4	105.2	19	47.8	61	3
1020G	4270	5600	78	26	15.9	177.8	127	62	105.2	126.5	19	59.4	77	3
1025G	7470	5000	98	32	29.5	212.7	159	77	130.6	154.9	21.8	71.6	92	5
1030G	12100	4400	111	39	43.1	239.7	187	91	152.4	180.3	21.8	83.8	107	5
1035G	18500	3900	134	51	68.0	279.4	219	106	177.8	211.3	28.4	97.5	130	6
1040G	30600	3600	160	64	97.5	317.5	247	121	209.6	245.4	28.4	111.3	145	6
1045G	42000	3200	183	77	136	346.1	278	135	235	274.1	28.4	122.9	166	8
1050G	56600	2900	200	89	191	388.9	314	153	254	305.8	38.1	140.7	183	8
1055G	74000	2650	220	102	249	425.4	344	168	279.4	334.3	38.1	158.0	204	8
1060G	90400	2450	244	115	306	457.2	384	188	304.8	366	25.4	169.2	229	8
1070G	135000	2150	289	127	485	527	451	221	355.6	424.9	28.4	195.6	267	10

Single-Acting Pancake Lock Nut Cylinders - CLP

جک هیدرولیکی یک طرفه کتابی مهره قفلی

CLP Series

- Capacity  
60-520 ton
- Stroke  
45-50 mm
- Maximum Operating Pressure  
700 bar



The Lowest Power Lifter



- Extremely Low height for use in confined areas.
- Lock nut for positive and safe load holding over a long period of time.
- Single-acting , load return.
- Optional special synthetic coating for improved corrosion resistance and lower friction for smoother operation to withstand side load forces up to 3% of rated cylinder capacity without scoring.
- Overflow port functions as a stroke limiter
- CR-400 coupler and dust cap included on all models

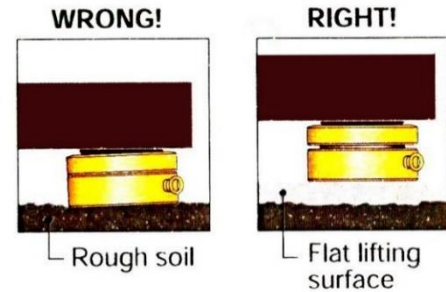

Model Number	Cylinder Capacity ton (Kn)	Stroke (mm)	Cylinder Effective Area (cm <sup>2</sup> )	Oil Capacity (cm <sup>3</sup> )	Collapsed Height A (mm)	Extended Height B (mm)	Outside Diameter D (mm)	Cylinder Bore Diameter E (mm)	Plunger Diameter F (mm)	Base to Adv. Port H (mm)
CLP-602	60 (606)	50	86.6	432	125	175	140	105.0	Tr 104x4	19
CLP-1002	100 (1027)	50	146.8	734	137	187	175	136.7	Tr 136x6	21
CLP-1602	160 (1619)	45	231.3	1040	148	193	220	171.6	Tr 171x6	27
CLP-2002	200 (1999)	45	285.6	1285	155	200	245	190.7	Tr 190x6	30
CLP-2502	260 (2567)	45	366.8	1650	159	204	275	216.1	Tr 216x6	32
CLP-4002	400 (3916)	45	559.5	2517	178	223	350	266.9	Tr 266x6	39
CLP-5002	520 (5114)	45	730.6	3287	192	237	400	305.0	Tr 305x6	48

Model Number	Saddle Diameter J (mm)	Saddle Protrusion from Plgr. K (mm)	Saddle Max. Tilt Angle R	Lock Nut Height S (mm)	(Kg)
CLP-602	96	6	5°	28	15
CLP-1002	126	8	5°	31	26
CLP-1602	160	9	5°	40	44
CLP-2002	180	10	5°	43	57
CLP-2502	200	11	5°	44	74
CLP-4002	250	11	4°	55	134
CLP-5002	290	10	3°	62	189

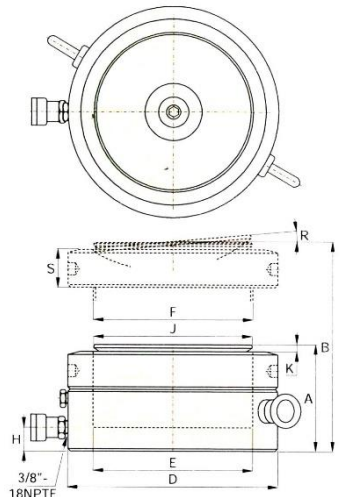

## RC – Series , Cylinders Accessories

لوازم جانبی جک هیدرولیکی یک طرفه

### RC Series

- Capacity  
5-95 ton
- Stroke  
16-362 mm
- Maximum Operating Pressure  
700 bar



### RC-Series, Cylinder Accessories

1) Standard on 5-30 ton RC-cylinders 2) Except RC-50 3) Except RC-101 4) Mounting screws are included 5) Used with Bender Sets

For use with cylinder capacity ton(kn)	Saddle			Base Plate	Mounting Block	Clevis Eyes	
	Flat	Grooved <sup>1)</sup>	Tilt			Base <sup>4)</sup>	Plunger
5 (45)	A-53F <sup>2)</sup>	A-53G <sup>2)</sup>	-	-	RB-5 <sup>2)</sup> , AW-51 <sup>2)</sup> , AW-53 <sup>2)</sup>	REB-5 <sup>2)</sup>	REP-5 <sup>2)</sup>
10 (101)	A-12 <sup>5)</sup> , A-102F <sup>3)</sup>	A-102G <sup>3)</sup>	CAT-10 <sup>3)</sup>	JBL-10	RB-10, AW-102	REB-10	REP-10 <sup>3)</sup>
15 (142)	-	A-152G	CAT-10	-	RB-15	REB-15	REP-10
25 (232)	A-29 <sup>5)</sup>	A-252G	CAT-50	JBL-25	RB-25	REB-25	REP-25
30 (295)	A-29 <sup>5)</sup>	A-252G	CAT-50	-	RB-25	-	REP-25
50 (498)	-	-	CAT-100	JBL-50	-	-	-
70 (718)	-	-	CAT-100	-	-	-	-
95 (933)	-	-	CAT-100	-	-	-	-

Model Nr.	Saddle Dimensions (mm)			A-53F, A-102F	A-12, A-29
	A	B	C		
<b>Flat</b>					
A-53F	25	6	17		
A-102F	35	6	22		
A-12	51	48	1"-8 UNC		
A-29	51	48	1 1/2"-16 UNC		
<b>Grooved</b>					
A-53G	25	6	17		
A-102G	35	6	22		
A-152G	38	9	22		
A-252G	50	9	35		

Model Nr.	Tilt Saddle Dimensions (mm)			
	A	B	C	
<b>Tilt</b>				
CAT-10	35	15	22	
CAT-50	50	23	35	
<b>Tilt</b>				
CAT-100	71	24	-	

Model Nr.	Base Plate Dimensions (mm)					
	A	B	C	D	E	
JBL-10	228	228	135	58	20	
JBL-25	279	279	140	86	26	
JBL-50	304	15	95	131	31	

Model Nr.	Mounting Block Dimensions (mm)							
	A	B	C	D	E	F	G	H
RB-5	1 1/2"-16	88	76	-	25	-	-	-
AW-51	1 1/2"-16	70	59	10	24	54	1/4"-20	41
AW-53	1 1/2"-16	72	7	7	19	57	1/4"-20	10
RB-10	2 1/4"-14	114	88	-	25	-	-	-
AW-102	2 1/4"-14	100	82	16	30	76	7/16"-20	58
RB-15	2 3/4"-16	101	114	-	38	-	-	-
RB-25	3 5/16"-12	127	165	-	50	-	-	-

Type	Model Nr.	Clevis Eye Dimensions (mm)					
		A	B	C	D	E	F
Base <sup>4)</sup>	REB-5	44	47	14	16	16	25
	REB-10	63	66	25	22	25	35
	REB-15	76	66	25	22	25	35
	REB-25	95	79	38	31	31	41
Plunger	REP-5	28	41	14	16	16	19
	REP-10	42	61	25	22	25	28
	REP-25	57	74	38	31	31	35

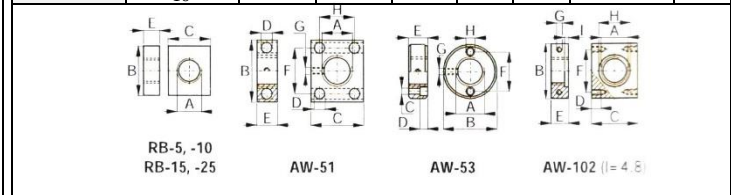

Single-Acting General Purpose Cylinders - RC

جک هیدرولیکی یک طرفه

Saddle Protr. from Plgr. K (mm)	Plunger Internal Thread O	Plunger Thread Length P (mm)	Base Mounting Holes			Collar Thread W	Collar Thread Length X (mm)	Model Number
			Bolt Circle U (mm)	Thread V	Thd. Depth Z (mm)			
-	-	-	28	5,6 mm	-	-	-	<b>RC-50</b>
6	3/4"-16	14	25	1/4"-20 UN	14	1 1/2"-16	28	<b>RC-51</b>
6	3/4"-16	14	25	1/4"-20 UN	14	1 1/2"-16	28	<b>RC-53</b>
6	3/4"-16	14	25	1/4"-20 UN	14	1 1/2"-16	28	<b>RC-55</b>
6	3/4"-16	16	25	1/4"-20 UN	14	1 1/2"-16	28	<b>RC-57</b>
6	3/4"-16	16	25	1/4"-20 UN	14	1 1/2"-16	28	<b>RC-59</b>
-	#10-24UN	6	39	5/16"-18 UN	12	2 1/4"-14	26	<b>RC-101</b>
6	1"-8	19	39	5/16"-18 UN	12	2 1/4"-14	28	<b>RC-102</b>
6	1"-8	19	39	5/16"-18 UN	12	2 1/4"-14	26	<b>RC-104</b>
6	1"-8	19	39	5/16"-18 UN	12	2 1/4"-14	28	<b>RC-106</b>
6	1"-8	19	39	5/16"-18 UN	12	2 1/4"-14	26	<b>RC-108</b>
6	1"-8	19	39	5/16"-18 UN	12	2 1/4"-14	28	<b>RC-1010</b>
6	1"-8	19	39	5/16"-18 UN	12	2 1/4"-14	26	<b>RC-1012</b>
6	1"-8	19	39	5/16"-18 UN	12	2 1/4"-14	26	<b>RC-1014</b>
9	1"-8	25	47	3/8"-16 UN	12	2 3/4"-16	30	<b>RC-151</b>
9	1"-8	25	47	3/8"-16 UN	12	2 3/4"-16	30	<b>RC-152</b>
9	1"-8	25	47	3/8"-16 UN	12	2 3/4"-16	30	<b>RC-154</b>
9	1"-8	25	47	3/8"-16 UN	12	2 3/4"-16	30	<b>RC-156</b>
9	1"-8	25	47	3/8"-16 UN	12	2 3/4"-16	30	<b>RC-158</b>
9	1"-8	25	47	3/8"-16 UN	12	2 3/4"-16	30	<b>RC-1510</b>
9	1"-8	25	47	3/8"-16 UN	12	2 3/4"-16	30	<b>RC-1512</b>
9	1"-8	25	47	3/8"-16 UN	12	2 3/4"-16	30	<b>RC-1514</b>
10	1 1/2"-16	19	58	1/2"-13 UN	19	3 5/16"-12	49	<b>RC-251</b>
10	1 1/2"-16	25	58	1/2"-13 UN	19	3 5/16"-12	49	<b>RC-252</b>
10	1 1/2"-16	25	58	1/2"-13 UN	19	3 5/16"-12	49	<b>RC-254</b>
10	1 1/2"-16	25	58	1/2"-13 UN	19	3 5/16"-12	49	<b>RC-256</b>
10	1 1/2"-16	25	58	1/2"-13 UN	19	3 5/16"-12	49	<b>RC-258</b>
10	1 1/2"-16	25	58	1/2"-13 UN	19	3 5/16"-12	49	<b>RC-2510</b>
10	1 1/2"-16	25	58	1/2"-13 UN	19	3 5/16"-12	49	<b>RC-2512</b>
10	1 1/2"-16	25	58	1/2"-13 UN	19	3 5/16"-12	49	<b>RC-2514</b>
10	1 1/2"-16	25	-	-	-	3 5/16"-12	49	<b>RC-308</b>
2	-	-	95	1/2"-13 UN	19	5"-12	55	<b>RC-502</b>
2	-	-	95	1/2"-13 UN	19	5"-12	55	<b>RC-504</b>
2	-	-	95	1/2"-13 UN	19	5"-12	55	<b>RC-506</b>
2	-	-	95	1/2"-13 UN	19	5"-12	55	<b>RC-5013</b>
5	-	-	-	-	-	5 3/4"-12	44	<b>RC-756</b>
5	-	-	-	-	-	5 3/4"-12	44	<b>RC-7513</b>
2	-	-	139	3/4"-10 UN	25	6 7/8"-12	44	<b>RC-1006</b>
2	-	-	139	3/4"-10 UN	25	6 7/8"-12	44	<b>RC-10010</b>

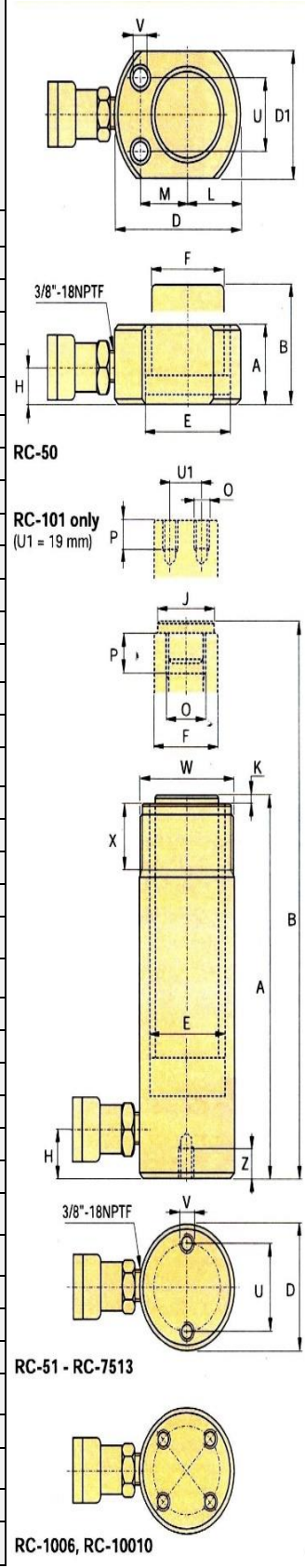

### RC Series Selection Chart

Model Number	Cylinder Capacity ton (Kn)	Stroke (mm)	Cylinder Effective Area (cm <sup>2</sup> )	Oil Capacity (cm <sup>3</sup> )	Collapsed Height A (mm)	Extended Height B (mm)	Outside Dia. D (mm)	Cylinder Bore Dia. E (mm)	Plunger Dia. F (mm)	Base to Adv. Port H (mm)	Saddle Dia. J (mm)	 (kg)
RC-50	5 (45)	16	6.5	10	41	57	58	28.7	25.4	19	-	1.0
RC-51		25	6.5	16	110	135	38	28.7	25.4	19	25	1.0
RC-53		76	6.5	50	165	241	38	28.7	25.4	19	25	1.5
RC-55		127	6.5	83	215	342	38	28.7	25.4	19	25	1.9
RC-57		177	6.5	115	273	450	38	28.7	25.4	19	25	2.4
RC-59		232	6.5	151	323	555	38	28.7	25.4	19	25	2.8
RC-101	10 (101)	26	14.5	38	89	115	57	42.9	38.1	19	-	1.8
RC-102		54	14.5	78	121	175	57	42.9	38.1	19	35	2.3
RC-104		105	14.5	152	171	276	57	42.9	38.1	19	35	3.3
RC-106		156	14.5	226	247	403	57	42.9	38.1	19	35	4.4
RC-108		203	14.5	294	298	501	57	42.9	38.1	19	35	5.4
RC-1010		257	14.5	373	349	606	57	42.9	38.1	19	35	6.4
RC-1012		304	14.5	441	400	704	57	42.9	38.1	19	35	6.8
RC-1014	356	14.5	516	450	806	57	42.9	38.1	19	35	8.2	
RC-151	15 (142)	25	20.3	51	124	149	69	50.8	41.4	19	38	3.3
RC-152		51	20.3	104	149	200	69	50.8	41.4	19	38	4.1
RC-154		101	20.3	205	200	301	69	50.8	41.4	19	38	5.0
RC-156		152	20.3	308	271	423	69	50.8	41.4	25	38	6.8
RC-158		203	20.3	411	322	525	69	50.8	41.4	25	38	8.2
RC-1510		254	20.3	516	373	627	69	50.8	41.4	25	38	9.5
RC-1512		305	20.3	619	423	728	69	50.8	41.4	25	38	10.9
RC-1514		356	20.3	723	474	830	69	50.8	41.4	25	38	11.8
RC-251	25 (232)	26	33.2	86	139	165	85	65.0	57.2	25	50	5.9
RC-252		50	33.2	166	165	215	85	65.0	57.2	25	50	6.4
RC-254		102	33.2	339	215	317	85	65.0	57.2	25	50	8.2
RC-256		158	33.2	525	273	431	85	65.0	57.2	25	50	10.0
RC-258		210	33.2	697	323	533	85	65.0	57.2	25	50	12.2
RC-2510		261	33.2	867	374	635	85	65.0	57.2	25	50	14.1
RC-2512		311	33.2	1033	425	736	85	65.0	57.2	25	50	16.3
RC-2514		362	33.2	1202	476	838	85	65.0	57.2	25	50	17.7
RC-308	30(295)	209	42.1	880	387	596	101	73.2	57.2	57	50	18.1
RC-502	50 (498)	51	71.2	362	176	227	127	95.2	79.5	33	71	15.0
RC-504		101	71.2	719	227	328	127	95.2	79.5	33	71	19.1
RC-506		159	71.2	1131	282	441	127	95.2	79.5	35	71	23.1
RC-5013	75 (718)	337	71.2	2399	460	797	127	95.2	79.5	35	71	37.6
RC-756		156	102.6	1601	285	441	146	114.3	95.2	30	71	29.5
RC-7513	333	102.6	3417	492	825	146	114.3	95.2	30	71	59.0	
RC-1006	95 (933)	168	133.3	2239	357	525	177	130.3	104.9	41	71	59.0
RC-10010		260	133.3	3466	449	709	177	130.3	104.9	41	71	72.6

Single-Acting Low Height Cylinders – RSM/RCS

جک هیدرولیکی یک طرفه کوتاه کتابی

RSM-RCS Series

- Capacity  
5-150 ton
- Stroke  
6-62 mm
- Maximum Operating Pressure  
700 bar



Maximum Power-to-Height Ratio



RSM Series , Flat-Jac Cylinders

- Compact, flat design for use where most other cylinders will not fit.
- Single-acting , spring return.
- RSM-750 , 1000 and 1500 have handles for easy carrying.
- Mounting holes permit easy fixturing.
- Baked enamel finish for increased corrosion resistance.
- CR-400 coupler and dust cap included on all models,except RSM-50 which is fitted with an AR-400 coupler.
- Har chrome plated high quality steel plungers.
- Grooved plunger ends require no saddle.

RCS Series , Low Height Cylinders

- Lightweight,low profile design for use in confined spaces.
- Single-acting , spring return .
- Baked enamel finish for increased corrosion resistance.
- Plunger wiper reduces contamination,extending cylinder life.
- CR-400 coupler and dust cap included on all models.
- Grooved plunger end with threaded holes for mounting tilt saddles.
- Integral handle on RCS-1002 for easy carrying.
- Plated steel plungers.

## Single-Acting Low Height Cylinders – RSM/RCS

## جک ہیدرولیکی یک طرفہ کوتاه کتابی

Model Number	Cylinder Capacity ton (Kn)	Stroke (mm)	Cyl. Effect. Area (cm <sup>2</sup> )	Oil Cap. (cm <sup>3</sup> )	Collapsed Height A (mm)	Extended Height B (mm)	Outside Dia. D (mm)	Cylinder Bore Dia. E (mm)	Plunger Dia. F (mm)	Base to Adv. Port H (mm)	 (kg)
RSM-50	5 (45)	6	6.5	4	32	38	58×41	28.7	25.4	16	1.0
RSM-100	10 (101)	12	14.5	18	43	54	82×55	42.9	38.1	19	1.4
RSM-200	20 (201)	11	28.7	32	51	62	101×76	60.5	50.8	19	3.1
RSM-300	30 (295)	13	42.1	55	58	71	117×95	73.2	63.4	19	4.5
RSM-500	45 (435)	16	62.1	99	66	82	140×114	88.9	69.8	19	6.8
RSM-750	75 (718)	16	102.6	164	79	95	165×139	114.3	82.6	19	11.3
RSM-1000	90 (887)	16	126.7	203	85	101	178×153	127.0	92.2	19	14.5
RSM-1500	150 (1386)	16	198.1	317	100	116	215×190	158.8	114.3	23	26.3
RCS-101	10 (101)	38	14.5	55	88	126	69	42.9	38.1	17	4.1
RCS-201	20 (201)	45	28.7	129	98	143	92	60.5	50.8	17	5.0
RCS-302	30 (295)	62	42.1	261	117	179	101	73.2	66.5	19	6.8
RCS-502	45 (435)	60	62.1	373	122	182	124	88.9	69.8	23	10.9
RCS-1002	90 (887)	57	126.7	722	141	198	165	127.0	92.2	31	22.7

Model Number	Plunger Protrusion From Base K (mm)	Plunger To Base L (mm)	Plunger To Mtg. Hole M (mm)	Thread O (mm)	Thread Depth P (mm)	Bolt Circle U (mm)
RSM-50	1	20	22	-	-	-
RSM-100	1	27	34	-	-	-
RSM-200	1	39	39	-	-	-
RSM-300	2	47	44	-	-	-
RSM-500	2	57	53	-	-	-
RSM-750	2	69	66	-	-	-
RSM-1000	2	76	74	-	-	-
RSM-1500	2	95	82	-	-	-
RCS-101	5	-	-	M4	8	26
RCS-201	3	-	-	M5	8	39
RCS-302	3	-	-	M5	8	39
RCS-502	2	-	-	M5	8	39
RCS-1002	1	-	-	M8	10	55

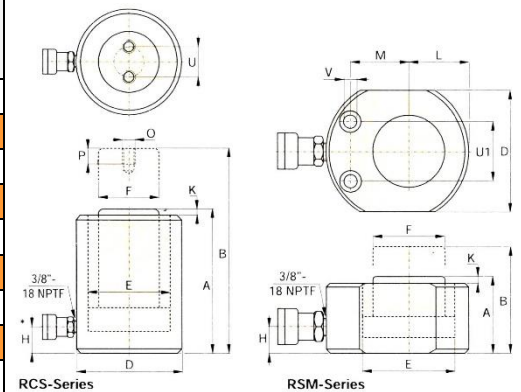

Optional Bolt On Tilt Saddle Dimensions (mm)				
For cyl. Model	Model Number	A	B	C
RCS-101	CAT-11	35	11	21
RCS-201,-302,-502	CAT-51	50	15	29
RCS-1002	CAT-101	71	17	35

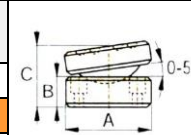

RSM Cylinder Mounting Hole Dimensions (mm)				
Model Number	Bolt Circle U1	Hole Dia. V	Counter Bore Dia.	Counter Bore Depth
RSM-50	28.5	5.5	9.1	4.3
RSM-100	36.6	7.1	10.7	7.9
RSM-200	49.3	10.0	15.1	9.9
RSM-300	52.3	10.0	15.9	11.2
RSM-500	66.5	11.0	19.0	12.7
RSM-750	76.2	13.5	20.6	14.2
RSM-1000	76.2	13.5	20.6	14.2
RSM-1500	117.3	13.5	20.6	14.2

Single-Acting Hollow Plunger Cylinders - RCH

جک هیدرولیکی یک طرفه توخالی

RCH Series

- Capacity  
13-95 ton
- Stroke  
8-155 mm
- Maximum Operating Pressure  
700 bar
- Center Hole Diameter  
19.6 – 79,0 mm



Versatility in Testing  
Maintenance  
And Tensioning  
Applications



- Hollow plunger design allows for both pull and push forces.
- Single-acting , spring return.
- Nickel-plated, floating center tube on models over 20 ton increases product life.
- Baked enamel finish for increased corrosion resistance.
- Collar threads for easy fixturing .
- RCH-120 includes AR-630 coupler and has 1/4" nptf port.
- RCH-121 and RCH-1211 have FZ-1630 reducer and AR-630 coupler, all other models feature CR-400 coupler.

Model Number	Cylinder Capacity ton (Kn)	Stroke (mm)	Cyl. Effect. Area (cm <sup>2</sup> )	Oil Cap. (cm <sup>3</sup> )	Coll. Height A (mm)	Ext. Height B (mm)	Out. Dia. D (mm)	Cyl. Bore Dia. E (mm)	Plgr. Dia. F (mm)	Cyl.Base To Advance Port H (mm)	Saddle Dia J (mm)	Weight (kg)
RCH-120	13 (125)	8	17.9	14	55	63	69	54.1	35.1	9	-	1.5
RCH-121		42	17.9	75	120	162	69	54.1	35.1	19	-	2.8
RCH-1211		42	17.9	75	120	162	69	54.1	35.1	19	-	2.8
RCH-123		76	17.9	136	184	260	69	54.1	35.1	19	-	4.4
RCH-202	20 (215)	49	30.7	150	162	211	98	73.1	54.1	19	54	7.7
RCH-206		155	30.7	476	306	461	98	73.1	54.1	25	54	14.1
RCH-302	30 (326)	64	46.6	298	178	242	114	88.9	63.5	21	63	10.9
RCH-306		155	46.6	722	330	485	114	88.9	63.5	25	63	21.8
RCH-603	60 (576)	76	82.3	626	247	323	159	123.9	91.9	31	91	28.1
RCH-606		153	82.3	1259	323	476	159	123.9	91.9	31	91	35.4
RCH-1003	95 (931)	76	133.0	1011	254	330	212	165.1	127.0	38	126	63.0



## Single – Acting Hollow Plunger Cylinders - RCH

## جک هیدرولیکی یک طرفه تو خالی

Model Number	Saddle Protrusion From Plgr. K (mm)	Plunger Internal Thread O	Plunger Thread Length P (mm)	Collar Thread W	Collar Thread Length X (mm)	Center Hole Dia. Y (mm)
RCH-120	-	3/4"-16 UN	16	2 3/4"-16	30	19.6
RCH-121	-	-	-	2 3/4"-16	30	19.6
RCH-1211	-	3/4"-16 UN	16	2 3/4"-16	30	19.6
RCH-123	-	-	-	2 3/4"-16	30	19.6
RCH-202	9.7	1 9/16"-16 UN	19	3 7/8"-12	38	26.9
RCH-206	9.7	1 9/16"-16 UN	19	3 7/8"-12	38	26.9
RCH-302	9.0	1 13/16"-16 UN	22	4 1/2"-12	42	33.3
RCH-306	9.0	1 13/16"-16 UN	22	4 1/2"-12	42	33.3
RCH-603	12.0	2 3/4"-16 UN	19	6 1/4"-12	48	53.8
RCH-606	12.0	2 3/4"-16 UN	19	6 1/4"-12	48	53.8
RCH-1003	12.0	4"-16 UN	25	8 3/8"-12	60	79.0

### Optional Heat Treated Hollow Saddles

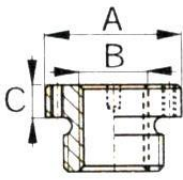
Saddle Type	Model Number	Saddle Model Nr.	Saddle Dimensions (mm)			
			A	B	C	
Threaded Hollow	RCH-202 , 206	HP-2015	53	1"-8	9	
	RCH-302 , 306	HP-3015	63	1 1/4"-7	9	
	RCH-603 , 606	HP-5016	91	1 5/8"-5 1/2	12	
	RCH-1003	HP-10016	126	2 1/2"- 8	13	

Smooth hollow saddles are standard on all RCH-models (except RCH-120 , RCH-1211).

### Base Mounting Hole Dimensions (mm)

Model Number	Bolt Circle U	Thread V	Thread Depth Z
RCH-120	50.8	5/16"- 18 UNC	9.0
RCH-121	-	-	-
RCH-1211	-	-	-
RCH-123	50.8	5/16"- 18 UNC	12.7
RCH-202	82.6	3/8"- 16 UNC	9.4
RCH-206	82.6	3/8"- 16 UNC	9.4
RCH-302	92.2	3/8"- 16 UNC	14.0
RCH-306	92.2	3/8"- 16 UNC	14.0
RCH-603	130.3	1/2"- 13 UNC	14.0
RCH-606	130.3	1/2"- 13 UNC	14.0
RCH-1003	177.8	5/8"- 11 UNC	19.0

RCH-121 and RCH-1211 have a 47 mm dia. boss that protrudes 6 mm from base.

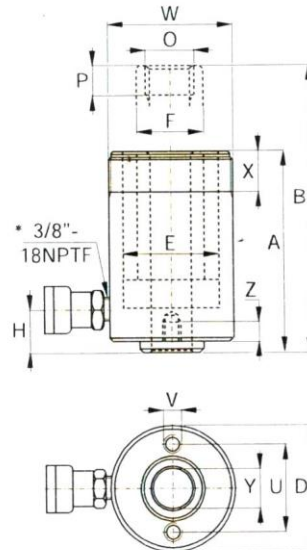

RCH-120 to RCH-123 models  
\* 1/4" NPT for RCH-120 only

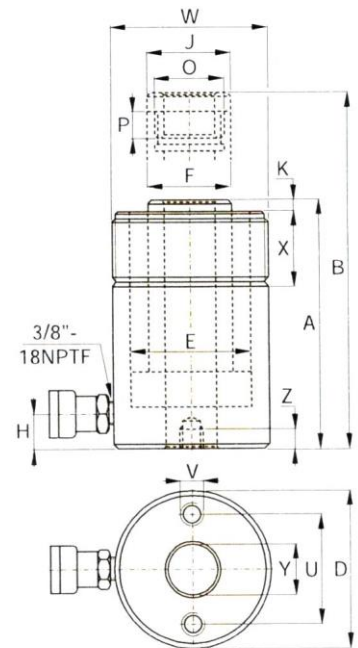

RCH-202 to RCH-1003 models

Double-Acting Hollow Stroke Cylinders - RRH

جک هیدرولیکی دو طرفه توخالی

RRH Series

- **Capacity**  
30-145 ton
- **Stroke**  
38-258 mm
- **Maximum Operating Pressure**  
700 bar
- **Center Hole Diameter**  
33.3 – 79,2 mm



Versatility in Testing

Maintenance

And Tensioning

Applications



- Relief valves prevent damage in case of over-pressurisation.
- Baked enamel finish for increased corrosion resistance
- Collar threads enable easy fixturing ( except RRH-1001 and RRH-1508)
- Double-acting version for fast retraction.
- Nickel-plated , floating center tube increases product life
- Hollow plunger allows for both pull and push forces
- CR-400 coupler and dust cap included on all models.
- Plunger wiper reduces contamination,extening cylinder life.

Model Number	storke (mm)	Capacity ton (Kn)	Max. Cylinder Capacity (Kn)		Cylinder Effective Area (cm <sup>2</sup> )		Oil Capacity (cm <sup>3</sup> )		Coll. Height A (mm)	Ext. Height B (mm)	Out. Dia D (mm)	⚖️ (kg)
			Advance	Retract	Advance	Retract	Advance	Retract				
RRH-307	178	30	326	213	46.6	30.4	829	541	330	508	114	21
RRH-3010	258		326	213	46.6	30.4	1202	784	431	689	114	27
RRH-603	89	60	576	380	82.3	54.2	733	482	247	336	159	28
RRH-606	166		576	380	82.3	54.2	1366	900	323	489	159	35
RRH-6010	257		576	380	82.3	54.2	2115	1393	438	695	159	45
RRH-1001	38	95	931	612	133.0	87.4	505	333	165	203	212	33
RRH-1003	76		931	612	133.0	87.4	1011	666	254	330	212	61
RRH-1006	153		931	612	133.0	87.4	2035	1337	342	495	212	79
RRH-10010	257		931	612	133.0	87.4	3420	2246	460	717	212	106
RRH-1508	203		145	1429	718	204.1	102.6	4144	2083	349	552	247

## Double-Acting Hollow Plunger Cylinders - RRH

## جک هیدرولیکی دو طرفه توخالی

Model Number	Cyl. Bore Dia. E (mm)	Plgr. Dia. F (mm)	Cyl. Base To Adv. Port H (mm)	Cyl. Top To Return port I (mm)	Saddle Dia. J (mm)	Saddle Protr. Fr. Plgr. K (mm)	Thread O (mm)	Plunger Thread Length P (mm)	Collar Thread W	Collar Thread Length X (mm)	Center Hole Dia. Y (mm)
RRH-307	88.9	63.5	25	60	63	9	1 <sup>13</sup> / <sub>16</sub> "- 16	22	4 <sup>1</sup> / <sub>2</sub> "- 12	42	33.3
RRH-3010	88.9	63.5	25	60	63	9	1 <sup>13</sup> / <sub>16</sub> "- 16	22	4 <sup>1</sup> / <sub>2</sub> "- 12	42	33.3
RRH-603	123.9	91.9	31	66	91	12	2 <sup>3</sup> / <sub>4</sub> "- 16	19	6 <sup>1</sup> / <sub>4</sub> "- 12	48	53.8
RRH-606	123.9	91.9	31	66	91	12	2 <sup>3</sup> / <sub>4</sub> "- 16	19	6 <sup>1</sup> / <sub>4</sub> "- 12	48	53.8
RRH-6010	123.9	91.9	31	66	91	12	2 <sup>3</sup> / <sub>4</sub> "- 16	19	6 <sup>1</sup> / <sub>4</sub> "- 12	48	53.8
RRH-1001	165.1	127.0	38	44	126	12	4"-16	25	-	-	79.2
RRH-1003	165.1	127.0	38	85	126	12	4"-16	25	8 <sup>3</sup> / <sub>8</sub> "- 12	60	79.2
RRH-1006	165.1	127.0	38	85	126	12	4"-16	25	8 <sup>3</sup> / <sub>8</sub> "- 12	60	79.2
RRH-10010	165.1	127.0	38	85	126	12	4"-16	25	8 <sup>3</sup> / <sub>8</sub> "- 12	60	79.2
RRH-1508	190.5	152.4	38	60	127	4	4 <sup>1</sup> / <sub>4</sub> "- 12	25	-	-	79.2

### Optional Heat Treated Hollow Saddles

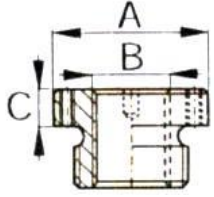
Saddle Type	Model Number	Saddle Model Nr.	Saddle Dimensions (mm)			
			A	B	C	
Threaded Hollow	RRH-307 , 3010	HP-3015	63	1 <sup>1</sup> / <sub>4</sub> "- 7	9	
	RRH-603 , 606 , 6010	HP-5016	91	1 <sup>5</sup> / <sub>8</sub> "- 5 <sup>1</sup> / <sub>2</sub>	12	
	RRH-1001 , 1003 , 1006 , 10010	HP-10016	126	2 <sup>1</sup> / <sub>2</sub> "- 8	13	

### Base Mounting Hole Dimensions (mm)

Model Number	Bolt Circle U	Thread V	Thread Depth Z
RRH-307	92.2	3/8"- 16	15.7
RRH-3010	92.2	3/8"- 16	15.7
RRH-603	130.0	1/2"- 13	14.0
RRH-606	130.0	1/2"- 13	14.0
RRH-6010	130.0	1/2"- 13	14.0
RRH-1001	177.8	5/8"- 11	19.0
RRH-1003	177.8	5/8"- 11	19.0
RRH-1006	177.8	5/8"- 11	19.0
RRH-10010	177.8	5/8"- 11	19.0
RRH-1508	-	-	-

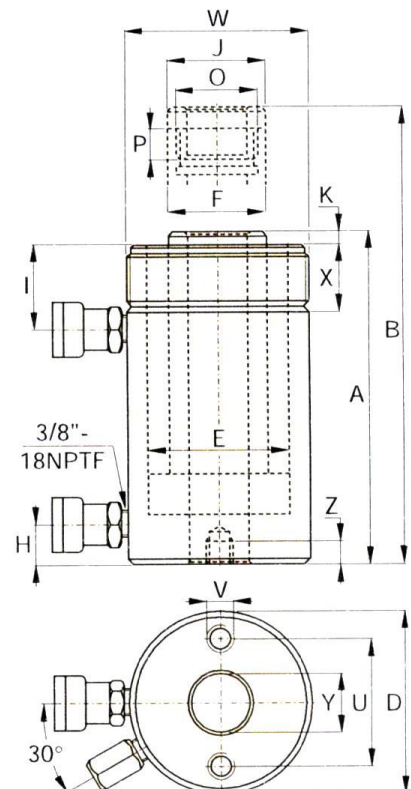

نمونه محصولات سفارشی



اکچویاتور فن هوایی



سیلندر هیدرولیک



بوش چدنی



پولی



پوسته سیلندر هیدرولیک



پلیت

## نمونه محصولات سفارشی



زنجر



زنجر



نازل اکسیژن



رینگ نگهدارنده



کوپلینگ بافردار



شافت

A large rectangular area with an orange border, containing 25 horizontal dotted lines for writing.

## برخی از مشتریان آرتیمان



شرکت بالایش گاز ایلام



شرکت بالایش نفت مکران



شرکت بالایش نفت اصفهان



شرکت بالایش نفت تبریز



شرکت بالایش گاز شهید داشی ناراد



شرکت بالایش نفت آبادان



شرکت بهره‌برداری نفت و گاز کرب



شرکت بهره‌برداری نفت و گاز مارون



شرکت بهره‌برداری نفت و گاز اصفهان



شرکت نفت پاسارگاد



شرکت مجتمع گاز پارس جنوبی



شرکت نفت مکران مرکزی ایران



شرکت انتقال گاز ایران



شرکت نفت مکران مرکزی ایران



شرکت فولاد خوزستان



ZAR SHOURAN



شرکت پتروشیمی جم



شرکت نفت ستاره خلیج فارس



شرکت نفت فلات قاره ایران



شرکت سکی مرکزی ایران



شرکت فکریه سینا مرکزی ایران



مجمع فولاد میاند



شرکت راکش کاری ترکتور سازی اصفهان



KSCCO



شرکت مدیریت تولید برق آذربایجان شرقی



شرکت مدیریت تولید برق شهید رجایی



Asia Pearlite Casting Industries co. شرکت صنایع پرتلیت آسیا



شرکت راهاندازی بهره‌برداری منابع نفت (کوکو)



شرکت آله‌میاتی ایران



تبریز، روبروی موتوژن، شهرک فناوری خودرو، پلاک ۲۷۶



[www.artimantools.com](http://www.artimantools.com)

۵۱۹۷۹-۱۳۷۵۶



[info@artimantools.com](mailto:info@artimantools.com)

۰۴۱-۳۴۴۷۴۷۴۱-۴۲



۰۴۱-۳۴۴۷۴۷۴۳

